

AdvanTex™ Treatment System - 1 tank Design For Enhanced
AX 20 Series - Mode 3a Enhanced Nitrogen Reduction

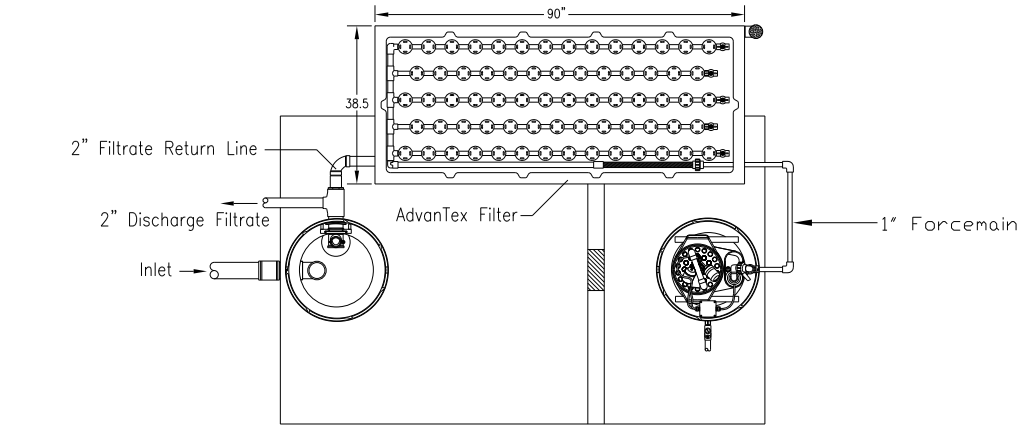

Water Tight Tankage Spec.
It Is Necessary That Tanks
Be Vacuum Or Water Tested
To Certify Water Tight Tankage.
PVC Access Risers Must Be
Water Tight, Epoxied To Tankage
And Bolted Down For Liability
Consideration. Contractor/Tank
Manufacturer Shall Be Responsible
For Repair Or Replacement
Of Tanks With Leaks or Defects.
Tankage Must Have 3 Year Warranty.



Top View

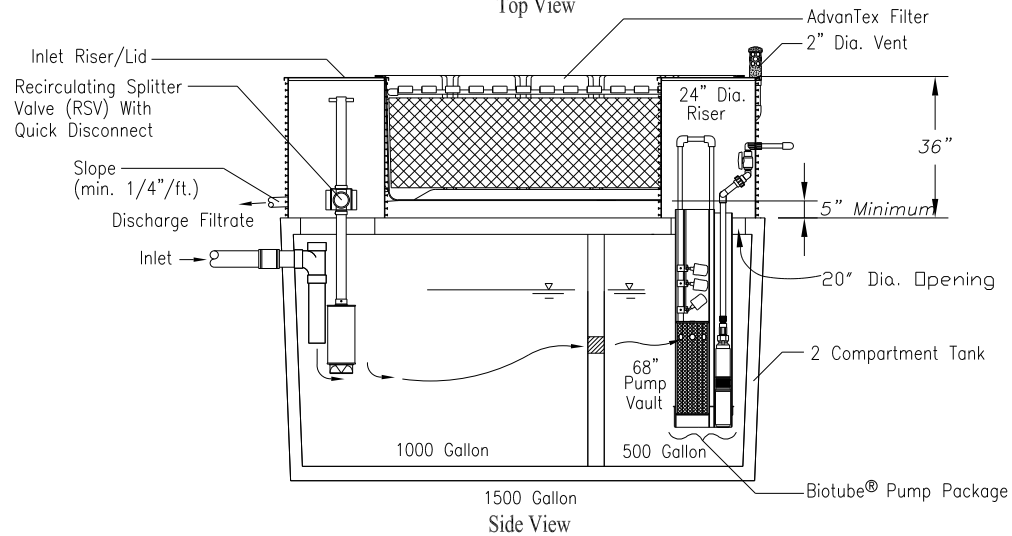

Side View

Patents # 4,439,323 & 5,492,635
Foreign Patents Pending
© Oreco Systems, Inc.

Note: Advantex and Piping must not settle

AX 20 Gravity (1 Tank)

DRAWING NO. A13	SHEET OF 1	NO	REVISION	DATE	BY
		1.	#1	10/15/07	
		2.			
		3.			
		4.			
5.					



7125 East Pickard Road
P. O. Box 309
Mt. Pleasant, MI 48804-0309
ph-989-773-9938
fax-989-772-3415

DRAWN	jdu
SCALE	
DATE	9/30/03
APPROVED	

