

AdvanTex™ Treatment System

AX 20 Series - Mode 3a



Oreco Systems®
Incorporated

Water Tight Tankage Spec.
It Is Necessary That Tanks
Be Vacuum Or Water Tested
To Certify Water Tight Tankage.
PVC Acces Risers Must Be
Water Tight, Epoxied To Tankage
And Bolted Down For Liability
Consideration. Contractor/Tank
Manufacturer Shall Be
Responsible
For Repair Or Replacement
Of Tanks With Leaks or Defects.

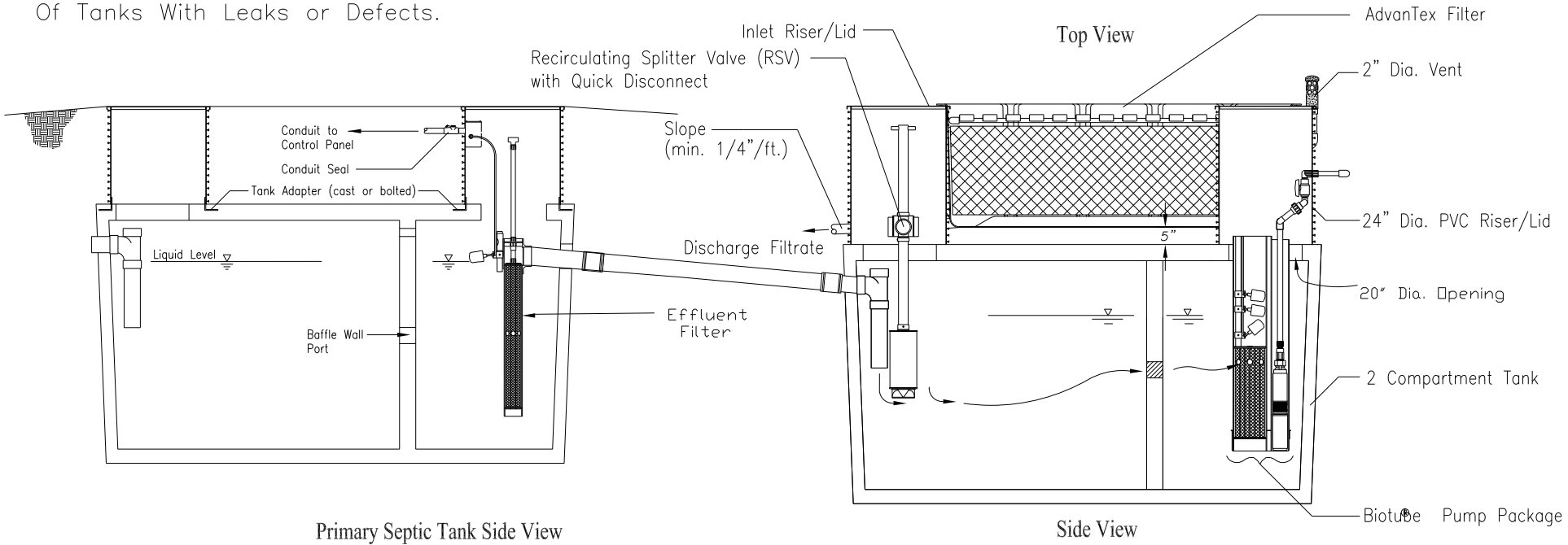
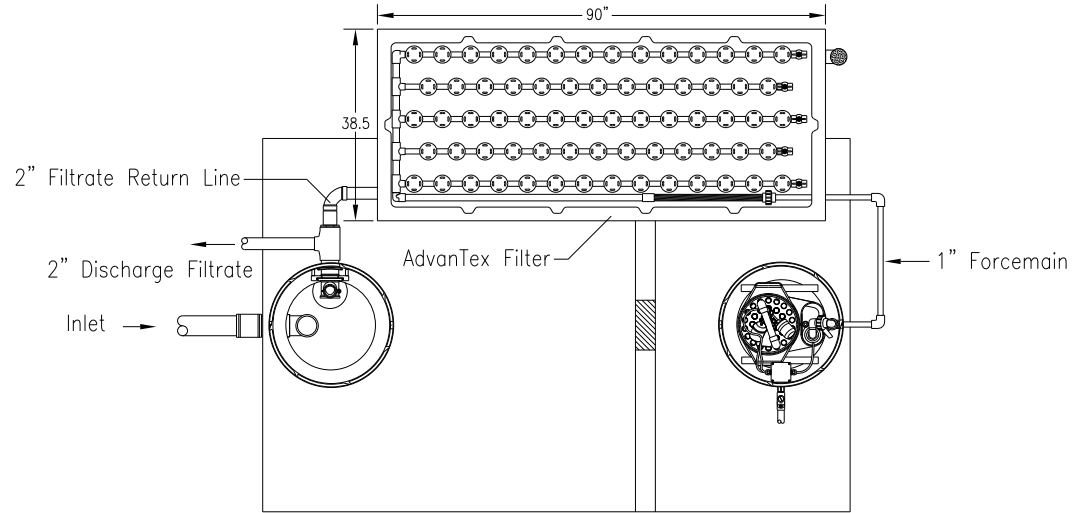

Primary Septic Tank Side View

Process Tank

Patents # 4,439,323 & 5,492,635
Foreign Patents Pending
© Oreco Systems, Inc.

Notes: Advantex and piping must not settle

File: A15 AX 20 Mode 3a(2 Tank, Gravity)

DRAWN	jdu
SCALE	
DATE	8/26/03
APPROVED	
7125 East Pickard Road P. O. Box 309 Mt. Pleasant, MI 48804-0309 ph-989-773-9938 fax-989-772-3415	
MILAN Engineered Systems	
BY	
DATE	
REVISION	
NO	1 2 3 4 5
SHEET	1
	OF
DRAWING NO.	A15

